

50Hz

iT0900 Ice Cube Machine

iT0900 Ice Cube Machine

Model: IRT0900A IYT0900A
 IDT0900A IRT0900W



Indigo NXT Series iT0900 Ice Machine on a D570 Bin

Designed for operators who know that ice is critical to their business, the Indigo®NXT Series ice machine's preventative diagnostics continually monitor itself for reliable ice production. Improvements in cleanability and programmability make your ice machine easy to own and less expensive to operate.

- **easyTouch® Display** - New icon based touch screen takes the guess work out of owning and operating an ice machine.
- **Multiple Language Capability** - The easyTouch display is available in multiple languages selected in the initial start-up installation Wizard.
- **Programmable Ice Production** - Now its super easy to program your ice machine to be off at certain times of the day to save money with fluctuating electrical rates. Also programmable by daily ice production volume.
- **Easy to Clean Foodzone** - Hinged front door swings out for easy access. Removable water-trough, distribution tube, curtain, and sensing probes for fast and efficient cleaning. Select components made with AlphaSan® antimicrobial.
- **Intelligent Diagnostics** - provide 24 hour preventative maintenance and diagnostic feedback for trouble free operation.
- **Acoustical Ice Sensing Probe** - Unique patented technology allows for reliable operation in challenging water conditions and environments.
- **DuraTech™ Exterior** - provides superior corrosion resistant above stainless steel. Innovative clear-coat resists fingerprints and dirt making it easier to keep clean.
- **Available Luminice II Virus and Bacteria Inhibitor**- Controls viruses, bacteria, mold and yeast within the foodzone to keep the machine clean longer. A new sanitation icon lets you know the operational status.
- **Active sense** - insures consistent ice harvest in all environmental conditions. This software and/or hardware solution works in conjunction with the acoustical ice sensing probe improving reliability and performance.

Specifications

BTU Per Hour:

12,700 (average)
14,800 (peak)

Refrigerant:

R410A CFC free 48% lower global warming

Operating Limits:

Ambient Temperature Range:
40 to 100 F (4.4 to 43.3 C)

Water Temperature Range:
40 to 90 F (4.4 to 32.2 C)

Water Pressure Ice Maker Water In:
Min. 20 psi (137.9 kPa)
Max. 80 psi (551.1 kPa)

Ice Machine Electric

230/50/1

Minimum circuit ampacity:

Air-cooled: 10.7 *1ph*
Water-cooled: 10.1 *1ph*

Maximum fuse size:

Air-cooled: 15 *1ph*
Water-cooled: 15 *1ph*

Machine Power Load:

Max: 1,724 W
Average: 1,422 W



Ice Shape



Half Dice
3/8" x 1 1/8" x 7/8"
(.95 x 2.86 x 2.22 cm)
Cube weight 5.7 g



Dice
7/8" x 7/8" x 7/8"
(2.22 x 2.22 x 2.22 cm)
Cube weight 8.5 g



Regular
1 1/8" x 1 1/8" x 7/8"
(2.86 x 2.86 x 2.22 cm)
Cube weight 14.2 g



COMPANY WITH QUALITY SYSTEM

6642A 06/19

Manitowoc Ice
2110
South 26 Steet
Manitowoc
Wisconsin, 54220
Tel: +1 800 545 5720
www.manitowocice.com



50Hz

iT0900 on D-570 Storage Bin

- (A) Electrical Entrance (2) Options
- (B) 3/8" (0.95 cm) F.P.T. Water Condenser Inlet (water-cooled units)
- (C) 1/2" (1.27 cm) F.P.T. Water Condenser Outlet (water-cooled units)
- (D) 1/2" (1.27 cm) Auxillary Base Drain Socket
- (E) 3/8" (0.95 cm) F.P.T. Ice Making Water Inlet
- (F) 1/2" (1.27 cm) F.P.T. Ice Making Water Drain
- (G) 3/4" (1.91 cm) Bin Drain

Installation Note
Minimum installation clearance:

Top/sides: 8" (20.32 cm); Back is 5" (12.7 cm)

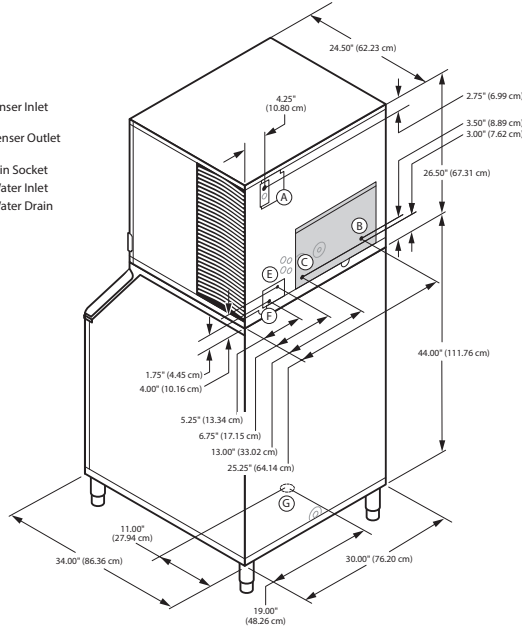

Space-Saving Designs



	iT0900 D-570	iT0900 D-970
Height	76.50" 194.30 cm	76.50" 194.30 cm
Width	30.00" 76.20 cm	48.00" 121.9 cm
Depth	34.00" 86.30 cm	34.00" 86.30 cm
Bin Storage	543 lbs. 241.1 kgs	882 lbs. 400.1 kgs

Height includes adjustable bin legs 6.00" to 8.00", (15.24 to 20.32 cm) set at 6.00" (15.24 cm).
Bin capacity is based on 90% of the volume x 33 lbs/ft³ average density of ice

Specification

		Ice Production 24 Hours				Power Usage kWh/ 45.4 kgs /100 lbs. @ 32°Air / 21°C Water 90°Air/70°F Water	Water Usage/100 lbs. 45.4 kgs. of Ice		
Model	Ice Shape	21°Air / 10°C water 70°Air/ 50°F Water		32°Air / 21°C Water 90°Air/ 70°F Water		1 Ph	Potable Water		
AIR-COOLED	IRT0900A	regular	765 lbs	347 kg	662 lbs	300 kg	4.62	19 Gal.	71.9 L
	IDT0900A	dice	840 lbs	381 kg	688 lbs	312 kg	4.61	19 Gal.	71.9 L
	IYT0900A	half-dice	833 lbs	378 kg	741 lbs	336 kg	4.59	19 Gal.	71.9 L
WATER-COOLED	IRT0900W	regular	735 lbs	333 kg	650 lbs	295 kg	4.57	19 Gal.	71.9 L

* Water-cooled Condenser Water Usage / 100 lbs. /45.4 kgs. Of Ice: 145 gal / 549 L.

Order ice storage bin separately.

Accessories

LuminIce® II Virus and Bacteria Inhibitor
controls viruses and bacteria inside the ice machine.



External Scoop holder

Protect the ice scoop with the NSF approved versatile scoop holder.



Arctic Pure® Water Filters

Reduces sediment and chlorine odors for better tasting ice.



iT0900 Ice Cube Machine

Manitowoc reserves the right to make changes to the design or specifications without prior notice

Manitowoc Ice
2110
South 26 Steet
Manitowoc
Wisconsin, 54220
Tel: +1 800 545 5720
www.manitowocice.com